

Operating instructions

English (Translation)

Dispense heads of the series

- M2-Series

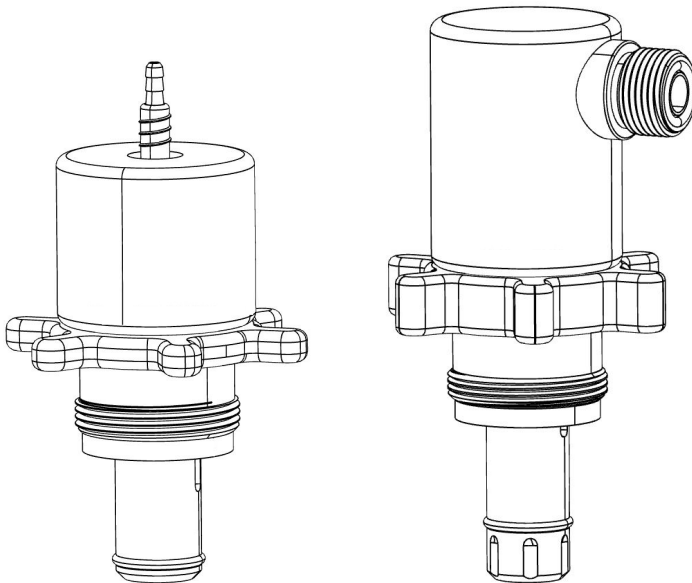

Legal notice

The operating instructions in German are the original operating instructions.
If you have questions about the products, please contact AS Strömungstechnik GmbH (manufacturer) directly.

Revision status: 01/2022

Copyright, address of the manufacturer:

© Copyright by
AS Strömungstechnik GmbH
Elly-Beinhorn-Str. 7
73760 Ostfildern
Germany

info@asstroemungstechnik.de
www.asstroemungstechnik.de

All rights reserved.
Printed in Germany.

Contents

1	General information	4
1.1	Introduction	4
1.2	Conventions	4
1.3	Symbols and labels	5
1.4	Copyright protection	5
1.5	Guarantee and warranty	5
2	Safety	6
2.1	Intended use	6
2.2	Improper use	6
2.3	Responsibility of the user	7
2.4	General safety instructions	7
3	Setup / function	8
3.1	Auxiliary tools	10
4	Technical specifications	11
4.1	Dispense head MH2-D.../MH2-D-...-C2	11
4.2	Ambient / operating temperature	13
4.3	Torques for dip tube closures	13
5	Assembly / commissioning	14
5.1	Initial commissioning	14
5.2	Tests prior to assembly	16
5.3	Mounting the dispense head	18
6	Operation	22
6.1	Tests before each operation	22
6.2	Tests during operation	22
7	Troubleshooting	23
8	Disassembly	24
8.1	Dismantling the dispense head	24
9	Maintenance / disposal	26
9.1	Cleaning the dispense head	26
9.2	Dispense head maintenance	26
9.3	Returning dispense heads	26
9.4	Dispense head disposal	27

1.1 Introduction

These operating instructions are only valid for the products mentioned in the title.

The figures shown are only exemplary illustrations. Depending on the equipment and configuration, the actual appearance of the dispense head may vary.

These operating instructions convey important notes for the safe and efficient handling of the products. They are part of the products. The prerequisite for safe working with the products is the compliance with all specified safety instructions and directives.

The operating instructions refer to standard versions. For special versions that are not described in these operating instructions, the basic information in these operating instructions applies in conjunction with additional special documentation.

The operating instructions are the basis for all training courses that take place with the products.

NOTICE

- Read the operating instructions carefully before using the products to avoid serious injury.
- Follow the safety instructions carefully to avoid serious injury.
- Store the operating instructions in a safe and accessible place during the service life of the products.
- Pass the operating instructions to any subsequent owner or user of the products.

1.2 Conventions

In order to be able to optimally work with the operating instructions, the following clarifications on typographical conventions must be observed.

List

- Texts displayed in this way are bullet points.

Handling instructions

1. Step 1 of the sequence of actions
2. Step 2 of the sequence of actions
3. Step 3 of the sequence of actions

The sequence of the work steps must be adhered to.

Tip

- » Indicates general information and recommendations.

1.3 Symbols and labels

The following symbols are used in these operating instructions to depict hazards and notes:

DANGER

Indicates a hazard which, if not avoided, will result in death or serious injury.

WARNING

Indicates a hazard which, if not avoided, could result in death or serious injury.

CAUTION

Indicates a hazard which, if not avoided, could result in minor or moderate injury.

NOTICE

Designates a situation that can result in material damage.

1.4 Copyright protection

Despite all care taken, data and characteristics can change – even at short notice. We therefore do not assume any liability or guarantee for the topicality, correctness and completeness of the information.

Figures, graphics and texts as well as the design of these operating instructions are subject to copyright protection and other protective laws. Duplication – also in excerpts – requires the prior written consent of AS Strömungstechnik GmbH, if duplication is not legally permitted.

1.5 Guarantee and warranty

AS Strömungstechnik GmbH assumes no liability for errors or damage that occurred due to improper handling of the products.

Improper handling is in particular in the event of non-compliance with the operating instructions, incorrect handling, negligence, unauthorized replacement of parts and other interventions.

The customer is responsible for testing the chemical resistance of the dispense heads and their service life.

Dispense heads and other products which have come into contact with media/chemicals (except ultra pure water) cannot be taken back.

AS Strömungstechnik GmbH reserves the right to make design changes due to further development of AS products.

Our customer service is always available even after the guarantee period has expired.

WARNING

Please observe the following notes to prevent malfunctioning, damage and injuries.

2.1 Intended use

The M2-Series dispense heads are designed for the clean and safe dispensing/ withdrawal of neutral or inorganic liquid chemicals from transport containers which do not adversely affect the physical and chemical properties of the materials and substances of which the dip tube used is composed.

NOTICE

The M2-Series conductive dispense heads are designed for the clean and safe dispensing/withdrawal of neutral or organic liquid chemicals from transport containers which do not adversely affect the physical and chemical properties of the materials and substances of which the dispense head used is composed. They are electrostatically safe in the sense of the Cenelec Technical Report TR 50404: 2003 and therefore applicable in zones 1 and 2 for liquids of the entire explosion group IIA.

Dispense heads may be used only in conjunction with AS dip tubes of the series corresponding to the dispense head. Observe the operating instructions of the dip tubes.

The dispense heads are designed for use with pump systems. For filling and recirculation applications, refer to the operating instructions for fill heads of the corresponding series.

2.2 Improper use

Any use other than the one described in the Section "intended use" is deemed to be inappropriate use. The operator of the products shall be solely responsible for any resulting damage.

2.3 Responsibility of the user

Operator means any natural or legal person who operates or controls the device or makes it accessible to third parties for use and who is responsible for the safety of the user or third parties.

- In particular, observe the general safety and occupational safety regulations of the BG Chemie in Germany or the responsible regional professional association for chemistry and health (e.g. OSHA in the United States), the applicable technical rules for hazardous substances, the Hazardous Substances Ordinance, the CLP Ordinance, the company own standard operating procedures (SOPs), as well as the regulations of the ATEX Directive, the technical guidelines “Flammable liquids” and the explosion protection guidelines of the BG Chemie in Germany or the responsible regional association / authority for applications in hazardous areas.
- These operating instructions do not replace the company’s own standard operating procedures (SOPs).
- Wear appropriate protective clothing when handling chemical substances.
- Do not use the dip tubes after the maximum period of use has expired, or else serious injury may occur. The duration of use depends on the chemicals used.
- Before using the products, check the materials for their chemical resistance.

2.4 General safety instructions

- Always observe the safety data sheets (SDS) of the chemicals used.
- Only use cleaned products. The products described in these operating instructions have been cleaned in an ultrasonic bath at the factory.
- Only use products for which the chemical resistance of the components is guaranteed.

3 Setup / function

In the M2-Series, the following dispense heads are available:

Abbr.	Description
MH2-D...	Dispense head with/without check valve, <ul style="list-style-type: none">• standard,• electrically conductive.
MH2-D...-C2	Dispense head with/without check valve, <ul style="list-style-type: none">• standard,• electrically conductive,• special version for Clorius2.

Depending on the design, the dispense head may look slightly different.

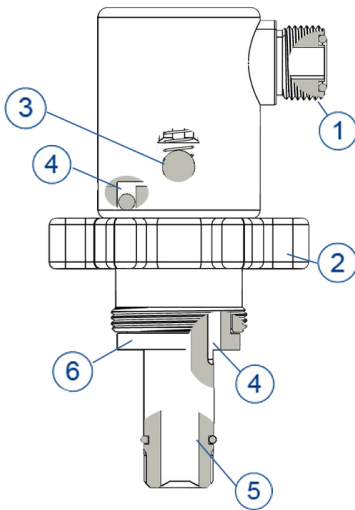

No.	Object
1	Liquid line connection
2	Tightening nut
3	Check valve (depending on model)
4	Vent channel
5	Liquid channel
6	Retaining ring
-	Code disk (not displayed/optional)

The dispense head is generally equipped with:

- Liquid line connection to inlet of fluid pump line connection,
- the tightening nut,
- standard connection to mating dip tube,
- the vent channel.

The check valve ensures that there is no flow back after transfer is complete and there is no spill at disconnection. As soon as the pump is activated, the check valve opens. When the pump is switched off, the negative pressure in the suction line is reduced and the check valve closes.

To remove flammable or highly flammable chemicals from a container, there is an electrically conductive version of the dispense head and the dip tube.

- » The MOC of electrically conductive plastic dispense heads and dip tubes is always black in color due to the carbon additive.

WARNING

Danger due to static charge.

Statically charged chemicals or dispense heads, dip tubes, etc. can cause sparks to arc creating an ignition source.

- Ground the dip tube and dispense head properly.

3.1 Auxiliary tools

The required auxiliary tools are listed below. For further details, please refer to the corresponding data sheet and our website.

Docking station (for wall mounting)

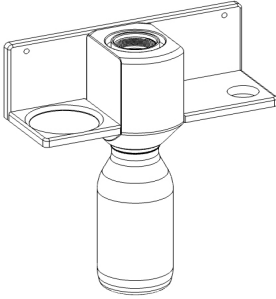

Series	Item no.	Note
QC2/M2	RDC-89740	incl. bottle
QC2/M2 conduc- tive	RDC-89740-CD	without shelf for accessories

Universal bung wrench

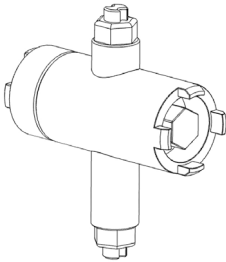

Series	Item no..	Note
QC2/M2	RDH-79005	PVDF
QC2/M2 conduc- tive	RDH-79003-CD	electrically conductive

Torque tool

The torque tool comes with torque wrench and attachment.

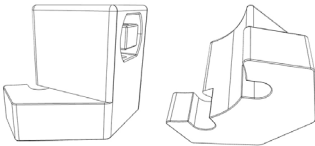

Series	Item no.
QC2/M2	DH-Z-2-0001-02

4 Technical specifications

4.1 Dispense head MH2-D.../MH2-D-...-C2

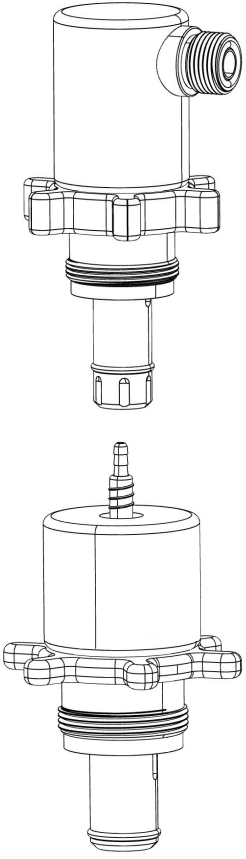
Characteristic	Value	Figure
Dimensions	See the corresponding data sheet for the dispense head.	
Weight		
Tightening torque [Nm]	M2-Series: 2.6	
Flow rates [l/min]	M2-Series: <ul style="list-style-type: none">• max. 2 (with check valve)	
Period of use	Depending on chemical resistance Standard: 2 years	

The dispense heads shown here are only exemplary representations. Depending on the equipment and configuration, the actual dispense head may vary in appearance.

4 Technical specifications

Materials (Wetted components)

Characteristic	Value
Housing variants	Standard (natural): PE-HD, PVDF Conductive: PP (black), PVDF (black)
O-ring variants	Standard: FPM/FKM, EPDM

Connections

Characteristic	Value
Connection variants liquid	Flare: 1/4" Hose Connector: 1/4" G-thread: 5/8"

- » Further information on the dispense heads can be found in the corresponding data sheets. Possible other versions are available on request.

4 Technical specifications

4.2 Ambient / operating temperature

Housing material	Temperature	
	Environment	Operation
PE-HD, PP	20-40 °C (68-104 °F)	20-40 °C (68-104 °F)
PVDF	20-60 °C (68-140 °F)	20-60 °C (68-140 °F)

For applications outside the listed temperature ranges, please contact the technical customer service of AS Strömungstechnik.

The chemical resistance of plastics and elastomers can deteriorate due to heat at temperatures higher than room temperature.

For dispense heads with built-in sensors (e.g. limit switch, bubble sensor), also observe the temperature specifications given in the sensor data sheet. These may further restrict the temperature ranges listed here.

4.3 Torques for dip tube closures

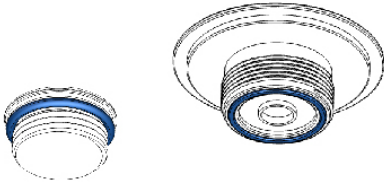

QC2/M2

Closure type	Torque
S-Typ/V-Typ (3/4" plug)	5-6 Nm
T-Typ/W-Typ (M42 plug).	6-8 Nm

In the containers onto which the dispense heads are mounted, there is already the dip tube on which the dispense head is mounted. The dip tube is possibly key-coded according to the liquid in the container and is tightly closed by means of the closure. Depending on the closure, it can also be closed with a tamper-proof cap. For the assembly described below, it is assumed that the closure is secured with a tamper-proof cap.

5.1 Initial commissioning

1. Make sure that the entire system is in a clean environment.

NOTICE

Contamination and debris can restrict the functionality of the entire system and lead to premature wear of o-rings and seals and thus to leaks. Dust deposits must be avoided in EX areas in particular, as there is an increased risk of ignition.

2. Connect the suction line to the liquid connection of the dispense head. The following must be observed here:
 - The suction line must be connected free of stress and load.
 - The connecting couplings must not be tightened too tight or too loose. Both can lead to leaks.
 - Please use recommended torque specifications of the respective manufacturer when tightening nuts and screws.
 - The screw connections must be secured against unwinding.
 - When using flare connections, see also AS flare and assembly instructions.
 - If the suction line is installed horizontally, it should be supported approx. 50 cm away from the dispense head.
 - The vibrations of the fluid pump must not be transmitted to the dispense head via the suction line.
 - The suction line should be as short as possible. This results in better suction performance.

3. Mount the dispense head on a container filled with ultra pure water. For assembly, see the section "Mounting the dispense head".
4. Perform a test run with ultra pure water and check the following points:
 - Tightness of the connections and interfaces,
 - Closing behavior of the valves; the valves (check valve, plug valve (turncock) or ball valve) must seal completely,
 - Ventilation of the container at maximum flow rate.
 - If no pressure range is available/measurable, visually check that the flow rate is constant and that the container does not inflate or collapse.

CAUTION

Danger due to leaks!

Exceeding the maximum flow rate can lead to leakage.

- Take suitable protective measures against exceeding the maximum flow rate.

5. Check/test the chemical resistance of the dispense head for the chemical used.
 - » On our website you will find a database with some data on chemical resistance, which can be used as a guide.
Link: <https://asstroemungstechnik.de/de/chembank>
6. Check whether the dispense head shows any damage such as cracks or discoloring.
7. Use the first liters of product as flushing chemistry to condition the dispense head and connections.

5.2 Tests prior to assembly

1. Use the label on the container to check whether the desired chemical is in the container.
 - » In addition, an electronic chemical comparison should be carried out via barcode or RFID.
2. Make sure that the container is placed in a dust-free environment.

NOTICE

Contamination and debris can limit the functionality of the dispense head and lead to premature wear of seals and thus to leaks.

3. Carry out a visual inspection for the following points:
 - Contamination and adhesion of chemical residues. The dispense head must be clean.
 - Make sure there is no damage such as cracks, etc.
4. Check the connecting couplings. They must not be too tight or too loose.
 - » Use the correct tightening torque that matches the screw connection. Please use recommended torque specifications of the respective manufacturer when tightening nuts and screws.
 - » The screw connections must be secured against unwinding. When using flare connections, see also AS flare and assembly instructions.

5 Assembly / commissioning

5. Check that the o-rings (1) and (2) are in place and undamaged (e.g. Cracks, tears, and residue are signs of damage) and that the venting channel (3) is clear of debris.

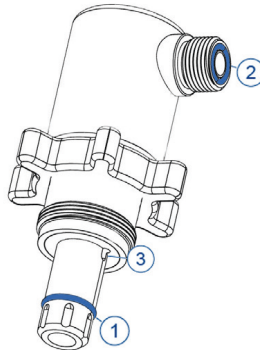

6. If a code disk is used check that the code disk (5) is on the dip tube and that the coding matches that of the dip tube (6) and thus the chemical. This means that only the correct three pins (7) must be missing and the code disk must not be bent.

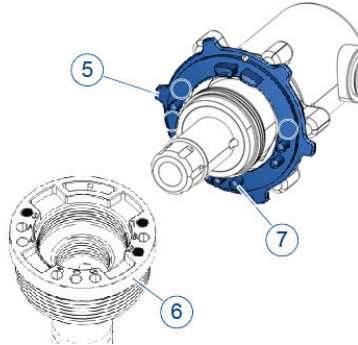

- » Do not change any coding on the dip tube or the code disk if they do not match. A list of the possible codings is available on request.
7. In the case of conductive dipse heads, check whether a conductive dip tube is installed and whether it is grounded. Follow the ATEX and OSHA instructions and regulations.
 - » For further information, please refer to the operating instructions of the dip tube.

5.3 Mounting the dispense head

WARNING

Hazard from chemicals!

Chemicals can cause irritation and chemical burns.

- Observe the proper Standard Operating Procedures (SOP) when handling hazardous substances.
- Observe the safety data sheets (SDS) of the chemicals used.
- Wear the necessary personal protective equipment (PPE) (suitable protective clothing, protective gloves, respirator and safety goggles / face shield).

1. If a tamper-proof cap is fitted to the dip tube closure of the container, remove the blue seal on the original tamper-proof cap (1).

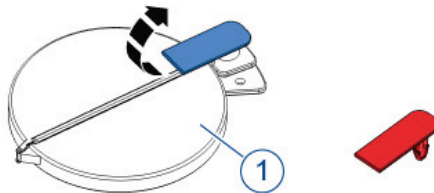

2. Open the tamper-proof cap and remove the red seal. Place both, if available, in the docking station on the system side (see Section 3.1).

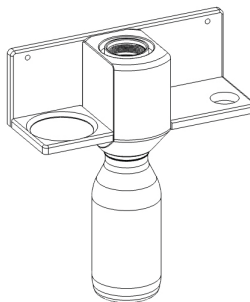

WARNING

Inhalation of chemical gases!

Inhalation of chemical gases is a health hazard.

- Open the container only while the chemical gas is being extracted.
- Please observe the applicable threshold limit values.
- Wear the necessary personal protective equipment (PPE) (suitable protective clothing, protective gloves, respirator and safety goggles / face shield).

3. Slowly open the dip tube closure (2) with the bung wrench (3) in case the contents are under pressure. (See Section 3.1)

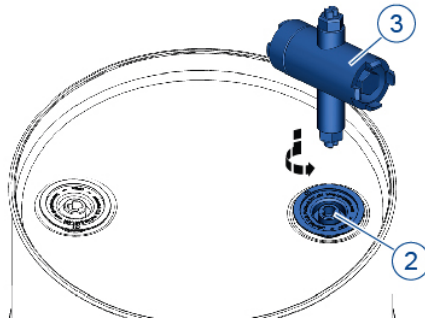

- » If the container is under pressure when opened, it is drained via the ventilation holes in the dip tube. You may hear a hissing sound. In this case, do not open the dip tube closure any further, but wait until no more hissing can be heard.
- » Check whether a bung wrench with a special chamber for neutralization granulate can be used so that the escaping gases can be additionally neutralized when opening.
- » If the chemical escapes when the container is opened, the container has been overfilled by the chemical filler. If this is the case, close the container again immediately and contact the chemical filler / manufacturer / supplier.

5 Assembly / commissioning

4. Remove the dispense head, if present, from the system-side docking station.
5. Wet the o-ring (4) with ultra pure water.

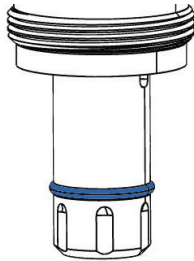

- » Wetting with ultra pure water minimizes sliding friction and protects the o-ring from damage.
6. Make sure that electrically conductive dispense heads are properly grounded with a ground wire and terminal.
 7. Insert the dispense head into the dip tube.

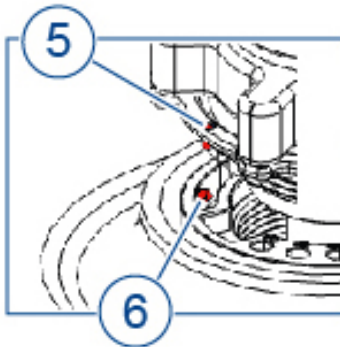

8. If a code disk is used align the code disk using the red or green orientation pins (5) and (6).
 - » The orientation pin of the dip tube and the code disk must be on top of each other.

NOTICE

The code disk must not be bent or damaged. Never mount the code disk using force.

9. Press the code disk into the recess of the dip tube.
10. Before screwing it on, make sure that the dispense head is not set at an angle to avoid tilting and damaging the threads.
11. Screw on the dispense head with the tightening nut (7) using the torque tool (8) (see Section 3.1) with the correct torque.
 - M2-Series: 2,6 Nm

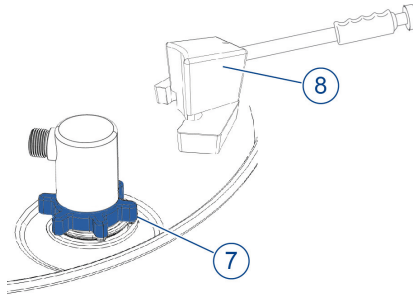

12. Check that the dispense head is completely and correctly mounted. This means that the dispense head must e.g. not be inserted at an angle.
 - » Check whether further precautions must be taken to ensure this, e.g. by using a dispense head with limit switch or by using a light barrier.
13. Check again that the head is correctly inserted and tightened.

NOTICE

If the head is not completely screwed on, air is sucked in when the chemical is removed. This will lead to the introduction of bubbles to the system that might affect the performance of instruments downstream or lead to a standstill of the system.

14. Check from all sides that the code disk lies flat on the dip tube (10).

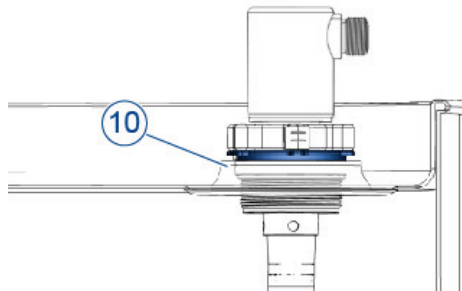

6.1 Tests before each operation

1. Make sure that minimal to no vibrations, e.g. from the fluid pump, are transmitted to the entire system.
2. For electrically conductive dispense heads, check that the entire system is grounded.
 - » Follow the ATEX and OSHA instructions and regulations.
3. Make sure that the dispense head is correctly mounted.
4. Operation can be started.

6.2 Tests during operation

- Check the flow rate and regulate it so that no negative or excess pressure can develop in the container.
If no pressure range is available/measurable, visually check that the flow rate is constant and that the container does not inflate or collapse.
- Check that minimal to no vibrations are transferred to the overall system.
- Carry out a visual inspection of the overall system for leaks or damages.

7 Troubleshooting

Error	Possible cause	Remedy
During operation, air bubbles appear in the suction line above the dispense head.	Lowermost o-ring on the dispense head, which separates the liquid channel from the vent channel, is damaged.	Replace o-ring.
	For chemicals with high vapor pressure (e.g. NH ₄ OH 28 %), an increased pressure drop in the suction line can lead to the formation of gas bubbles or the liquid column can break off.	Shorten the suction line, Use of a dispense head with manual shut-off valve.
Container contracts during operation and/ or when the system is stopped.	Vent channel of the dispense head closed or not free.	Clean the dispense head, e.g. in an ultrasonic cleaner.
	Ventilation of the container is not sufficient to achieve complete pressure equalization.	Reduce the dispensing flow rate of the operating medium.
Dispense head can only be screwed into the dip tube at an angle or not completely.	Thread on dip tube damaged.	Contact chemical filler / manufacturer / supplier or technical customer service of AS Strömungstechnik.
	Thread on the dispense head damaged.	Contact AS Strömungstechnik technical customer service, send in the dispense head for repair, see Section 9.3.
Operating medium escapes from dispense head inlet (liquid channel).	Contaminations/deposits in the valve.	Clean/rinse the dispense head.
	Valve body or seal damaged.	Contact AS Strömungstechnik technical customer service, send in the dispense head for repair, see Section 9.3.

8.1 Dismantling the dispense head

WARNING

Hazard from chemicals!

Chemicals can cause irritation and chemical burns.

- Observe the proper Standard Operating Procedures (SOP) when handling hazardous substances.
- Observe the safety data sheets (SDS) of the chemicals used.
- Wear the necessary personal protective equipment (PPE) (suitable protective clothing, protective gloves, respirators and safety goggles / face shield).

1. Make sure that there is no negative pressure in the suction line.
 - » Negative pressure in the suction line will cause air to flow in and chemical residue to be blown out of the dispense head or the line to be filled with air.
2. Slowly unscrew the dispense head via the tightening nut.
 - » If the container is under any pressure or vacuum when opened, it is drained via the ventilation hole in the dip tube. You may hear a hissing sound. In this case, do not continue unscrewing the dispense head, wait until no more hissing can be heard and then finish unscrewing.
3. Pull the dispense head out of the dip tube until the dispense head is above the dip tube opening.

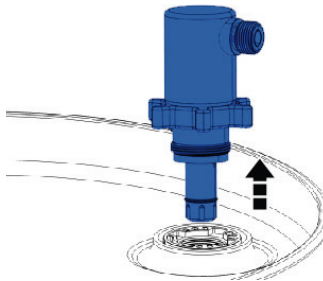

4. Wait a few seconds so that condensate, for example, can still drip into the container.
5. Rinse and clean the dispense head with ultra pure water.
6. Insert the dispense head, if present, into the docking station on the system side.
7. Screw the dispense head in tight into the docking station.

8 Disassembly

8. Check that the o-ring on the dip tube closure is present and undamaged.

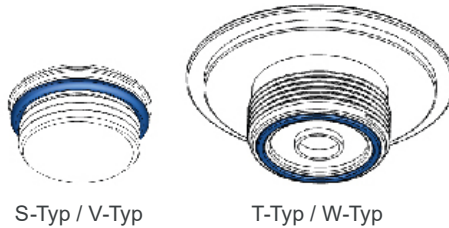

9. Place the dip tube closure on the dip tube opening.
10. Close the container by screwing on the dip tube closure (2) hand-tight using the bung wrench (3) (see Section 3.1).

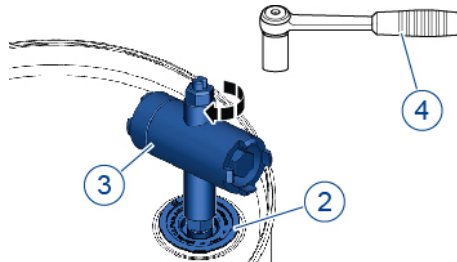

11. Take a torque wrench (4), place it on the bung wrench (3). Tighten the dip tube closure (2) to the correct torque.
 - » See the table with the torques in Section 4.3.
12. Close the dip tube closure with the tamper-proof cap and seal it with the red seal.



9.1 Cleaning the dispense head

- After disassembly, the liquid channel of the dispense head must be flushed with ultra pure water or a suitable flushing medium.
- In the case of hardening, adhesive and clumping chemicals, we recommend flushing the entire delivery line with ultra pure water or a suitable flushing medium after each use.
- If necessary, wash the dispense head from the outside with ultra pure water or a suitable rinsing medium.

9.2 Dispense head maintenance

The following checks must be carried out regularly, at least monthly, in addition to the checks during assembly:

Component	Testing
Dispense head	Check regularly for discoloration and damage.
Check valve	Regular functionality check.
O-rings on the dispense head	Regularly check for wear and tear and replace if necessary.
Electrical conductivity	For CD version, check conductivity regularly (may change due to exposure to chemicals).
O-ring on check valve	Regularly check whether the check valve seals completely.
Dispense head	Regularly check the connections for proper screw connections.

9.3 Returning dispense heads

1. Disassemble the dispense head (see Section "8.1").
2. Clean the disassembled dispense head (see Section 9.1).
3. Request a decontamination certificate from AS Strömungstechnik.
4. Return the completed decontamination certificate to AS Strömungstechnik.
 - » If the decontamination certificate is not properly and completely filled out, there will be no credit provided or repair. A disposal cost will be applied. It is important to fill out the form for the safety of our personnel as well as the safety of logistic providers.

9.4 Dispense head disposal

WARNING

Hazard from chemicals!

Chemicals can cause irritation and chemical burns.

- Observe residual debris and degassing of diffused chemicals
- Observe the safety data sheets (SDS) of the chemicals used.

1. Disassemble the dispense head (see Section “8.1”).
2. Clean the disassembled dispense head (see Section 9.1).
3. Dispose of all parts in an environmentally correct manner.



Incorrect or negligent disposal can cause considerable environmental pollution.

- Disposal must take place in accordance with the applicable national rules and regulations.

In case of doubt, consult the manufacturer or obtain information on the environmentally responsible disposal from the local authorities or disposal specialists.