

Operating instructions

English (Translation)

Fill heads of the series

- QC2
- G-Series

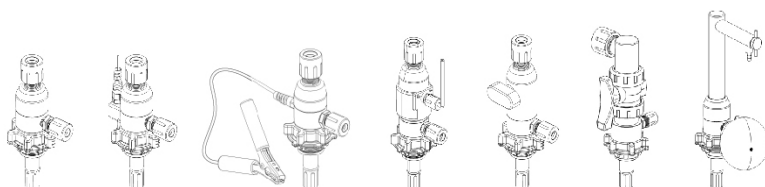
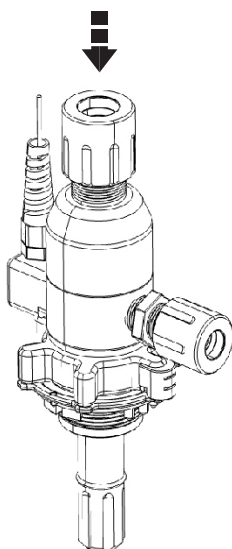

Legal notice

The operating instructions in German are the original operating instructions.
If you have questions about the products, please contact AS Strömungstechnik GmbH (manufacturer) directly.

Revision status: 10/2023

Copyright, address of the manufacturer:

© Copyright by
AS Strömungstechnik GmbH
Elly-Beinhorn-Str. 7
73760 Ostfildern
Germany

info@asstroemungstechnik.de
www.asstroemungstechnik.de

All rights reserved.
Printed in Germany.

1	General information	4
1.1	Introduction	4
1.2	Conventions	4
1.3	Symbols and labels	5
1.4	Copyright protection	5
1.5	Guarantee and warranty	5
2	Safety	6
2.1	Intended use	6
2.2	Improper use	6
2.3	Responsibility of the user	7
2.4	General safety instructions	7
3	Setup / function	8
3.1	Auxiliary tools	11
4	Technical specifications	12
4.1	Fill head DH-R.../GH-R	12
4.2	Fill head DH-_B.../GH-_B	14
4.3	Fill head DH-A.../GH-A	16
4.4	Fill head DH-...-N2 / GH-...-N2	18
4.5	Fill head DH-_U... / GH-_U	20
4.6	Fill head DH-_J... / DH-_J... / GH-_J... / GH-J	22
4.7	Ambient / operating temperature	24
4.8	Torques for dip tube closures	24
5	Assembly / commissioning	25
5.1	Initial commissioning	25
5.2	Tests prior to assembly	28
5.3	Mounting the fill head	31
6	Operation	35
6.1	Tests before each operation	35
6.2	Tests during operation	35
7	Troubleshooting	36
8	Disassembly	37
8.1	Dismantling the fill head	37
9	Maintenance / disposal	40
9.1	Cleaning the fill head	40
9.2	Fill head maintenance	40
9.3	Returning fill heads	41
9.4	Fill head disposal	41

1.1 Introduction

These operating instructions are only valid for the products mentioned in the title.

The figures shown are only exemplary illustrations. Depending on the equipment and configuration, the actual appearance of the dispense head may vary.

These operating instructions convey important notes for the safe and efficient handling of the products. They are part of the products. The prerequisite for safe working with the products is the compliance with all specified safety instructions and directives.

The operating instructions refer to standard versions. For special versions that are not described in these operating instructions, the basic information in these operating instructions applies in conjunction with additional special documentation.

The operating instructions are the basis for all training courses that take place with the products.

NOTICE

- Read the operating instructions carefully before using the products to avoid serious injury.
- Follow the safety instructions carefully to avoid serious injury.
- Store the operating instructions in a safe and accessible place during the service life of the products.
- Pass the operating instructions to any subsequent owner or user of the products.

1.2 Conventions

In order to be able to optimally work with the operating instructions, the following clarifications on typographical conventions must be observed.

List

- Texts displayed in this way are bullet points.

Handling instructions

1. Step 1 of the sequence of actions
2. Step 2 of the sequence of actions
3. Step 3 of the sequence of actions

The sequence of the work steps must be adhered to.

Tip

- » Indicates general information and recommendations.

1.3 Symbols and labels

The following symbols are used in these operating instructions to depict hazards and notes:

DANGER

Indicates a hazard which, if not avoided, will result in death or serious injury.

WARNING

Indicates a hazard which, if not avoided, could result in death or serious injury.

CAUTION

Indicates a hazard which, if not avoided, could result in minor or moderate injury.

NOTICE

Designates a situation that can result in material damage.

1.4 Copyright protection

Despite all care taken, data and characteristics can change – even at short notice. We therefore do not assume any liability or guarantee for the topicality, correctness and completeness of the information.

Figures, graphics and texts as well as the design of these operating instructions are subject to copyright protection and other protective laws. Duplication – also in excerpts – requires the prior written consent of AS Strömungstechnik GmbH, if duplication is not legally permitted.

1.5 Guarantee and warranty

AS Strömungstechnik GmbH assumes no liability for errors or damage that occurred due to improper handling of the products.

Improper handling is in particular in the event of non-compliance with the operating instructions, incorrect handling, negligence, unauthorized replacement of parts and other interventions.

The customer is responsible for testing the chemical resistance of the dispense heads and their service life.

Dispense heads and other products which have come into contact with media/chemicals (except ultra pure water) cannot be taken back.

AS Strömungstechnik GmbH reserves the right to make design changes due to further development of AS products.

Our customer service is always available even after the guarantee period has expired.

WARNING

Please observe the following notes to prevent malfunctioning, damage and injuries.

2.1 Intended use

The QC2 and G-Series fill heads are designed for the clean and safe filling/recirculation of neutral or inorganic liquid chemicals into transport containers which do not adversely affect the physical and chemical properties of the materials and substances of which the fill head used is composed.

NOTICE

The QC2 and G-Series conductive fill heads are designed for the clean and safe filling/recirculation of neutral or organic liquid chemicals into transport containers which do not adversely affect the physical and chemical properties of the materials and substances of which the fill head used is composed. They are electrostatically safe in the sense of the Cenelec Technical Report TR 50404: 2003 and therefore applicable in zones 1 and 2 for liquids of the entire explosion group IIA.

Fill heads may be used only in conjunction with AS dip tubes of the series corresponding to the fill head. Observe the operating instructions of the dip tube.

The fill heads are designed for use with pump systems.

For dispensing and withdrawal applications, refer to the operating instructions for dispense heads of the corresponding series.

2.2 Improper use

Any use other than the one described in the Section “intended use” is deemed to be inappropriate use. The operator of the products shall be solely responsible for any resulting damage.

2.3 Responsibility of the user

Operator means any natural or legal person who operates or controls the device or makes it accessible to third parties for use and who is responsible for the safety of the user or third parties.

- In particular, observe the general safety and occupational safety regulations of the BG Chemie in Germany or the responsible regional professional association for chemistry and health (e.g. OSHA in the United States), the applicable technical rules for hazardous substances, the Hazardous Substances Ordinance, the CLP Ordinance, the company own standard operating procedures (SOPs), as well as the regulations of the ATEX Directive, the technical guidelines “Flammable liquids” and the explosion protection guidelines of the BG Chemie in Germany or the responsible regional association / authority for applications in hazardous areas.
- If flammable liquids are “splash filled” into the container, the applicable national and international regulations and guidelines must also be observed (e.g. BetrSichV incl. TRBS 2153, 4/2009 (Germany), Cenelec Technical Report TR 50404: 2003 (EU), IEC 60079-32 (international), JNIOH-TR-No.42 2007 (Japan), NFPA Recommended Practice on Static Electricity (USA). It must also be checked whether a correspondingly long dip tube can be used for the return / filling into the container, which enables filling below the liquid level.
- These operating instructions do not replace the company’s own standard operating procedures (SOPs).
- Wear appropriate protective clothing when handling chemical substances.
- Ensure that the fill heads are not used after the maximum period of use has expired. The duration of use depends on the chemicals used.
- Before using the products, check the materials for their chemical resistance.

2.4 General safety instructions

- Always observe the safety data sheets (SDS) of the chemicals used.
- Only use cleaned products. The products described in these operating instructions have been cleaned in an ultrasonic bath at the factory.
- Only use products for which the chemical resistance of the components is guaranteed.

3 Setup / function

In the QC2 and G-Series, the following fill heads are available:

Abbr.	Description
DH-R... GH-R...	Fill head with/without check valve <ul style="list-style-type: none">• Standard,• electrically conductive.
DH-_B... GH-_B...	Fill head with limit switch
DH-A... GH-A...	Fill head with manual shut-off valve <ul style="list-style-type: none">• Plug valve (turncock)• Ball valve
DH-J... DH-_J... GH-J... GH-_J...	Fill head with mixing nozzle
DH-...-N2 GH-...-N2	Fill head with second vent port for N2-blanketing
DH-_U... GH-_U...	Fill head with overfilling sensor

- » Fill head versions can be combined with each other.
For example, a QC2 Fill head can also have a check valve, a limit switch and an overfilling sensor (DH-RBU-...).
The electrically conductive version with limit switch, manual shut-off valve or second vent port is also available.

Depending on the design, the fill head may look slightly different.

3 Setup / function

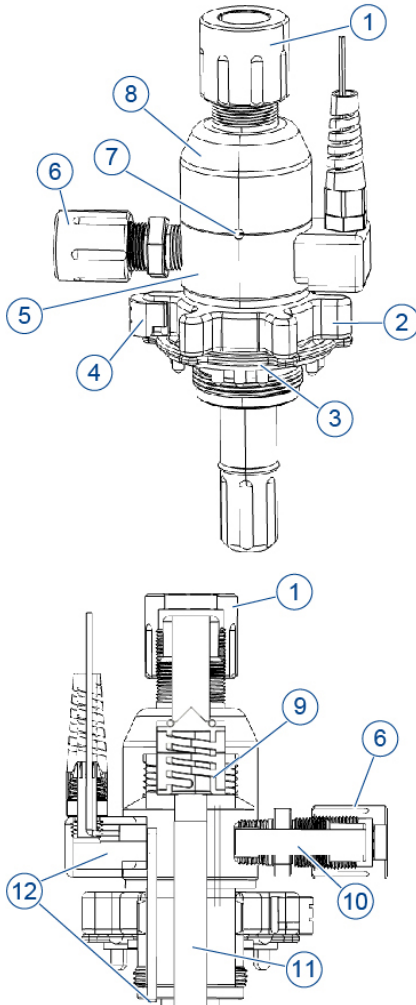

No.	Object
1	Liquid line connection
2	Tightening nut (incl. red markings)
3	Code disk
4	Anti-rotation clip (red)
5	Main body
6	Vent port standard: NPT3/8" female thread (from 11/2019), on the Figure with screwed-in flare adapter.
7	Locking pin (set screw)
8	Top connection (vertical or horizon- tal)
9	Check valve (depending on model)
10	Vent channel
11	Liquid channel
12	Limit switch (optional)

The fill head is generally equipped with:

- Liquid line connection to inlet of fluid pump line connection
- Vent line connection
- Code disk
- Tightening nut with red anti-rotation clip
- Standard connection to mating dip tube

Depending on the option, the fluid flow rate in the liquid channel can be controlled by a check valve, a plug valve (turncock) or a ball valve.

The check valve ensures that there is no flow back after transfer is complete and there is no spill at disconnection. As soon as the pump is activated, the check valve opens. When the pump is switched off, the pressure in the filling line is reduced and the check valve closes.

The optional limit switch ensures that the fill head is correctly mounted. The filling process can only be started after the release signal from the limit switch.

- » The incorporation of the limit switch requires professional installation to integrate the signals into the system control (PLC) to properly operate.

To fill flammable or highly flammable chemicals into a container, there is an electrically conductive version of the fill head and the dip tube.

- » The MOC of electrically conductive plastic fill heads and dip tubes is always black in color due to the carbon additive.

WARNING

Danger due to static charge.

Statically charged chemicals or fill heads, dip tubes, etc. can cause sparks to arc creating an ignition source.

- Ground the dip tube and fill head properly.

3 Setup / function

3.1 Auxiliary tools

The required auxiliary tools are listed below. For further details, please refer to the corresponding data sheet and our website.

Docking station (for wall mounting)

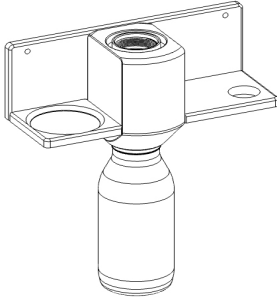

Series	Item no.	Note
QC2	RDC-89740	incl. bottle
QC2 conduc- tive	RDC-89740-CD	without shelf for accesso- ries
G-Series	RDC-89750	incl. bottle
G-Series conduc- tive	RDC-89754	without shelf for accesso- ries

Universal bung wrench

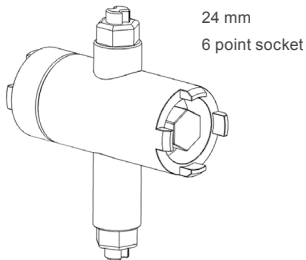

Series	Item no.	Note
QC2	RDH-79005	PVDF
QC2 conduc- tive	RDH-79003-CD	electrically conductive
G-Series	RDH-79010	PVDF
G-Series conduc- tive	RDH-79009	electrically conductive

Torque tool

The torque tool comes with torque wrench and attachment.

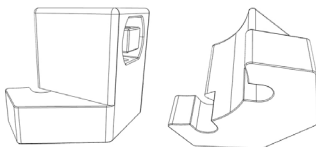

Series	Item no.
QC2	DH-Z-2-0001-02
G-Series	DH-Z-G-0001-02

4 Technical specifications

4.1 Fill head DH-R.../GH-R...

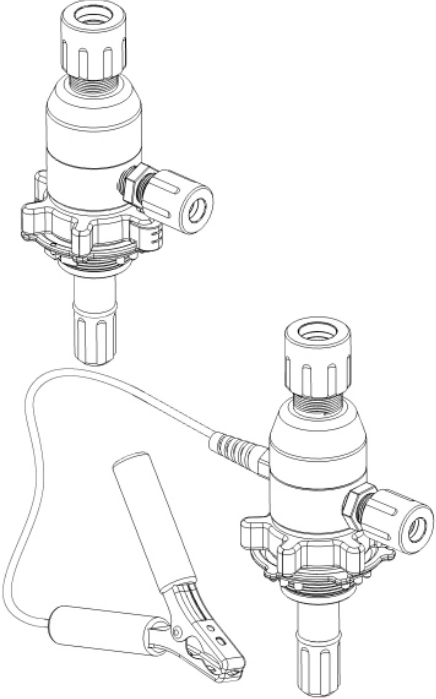
Characteristic	Value	Figure
Dimensions	See the corresponding data sheet for the fill head.	
Weight		
Tightening torque [Nm]	QC2: 2.6 G-Series: 2.6	
Flow rates [l/min]	QC2: <ul style="list-style-type: none">• max. 25 (with check valve)• max. 60 (without check valve) G-Series: <ul style="list-style-type: none">• max. 100 (with check valve)• max. 150 (without check valve)	
Opening pressure check valve [bar]	QC2: 0.10 G-Series: 0.05	
Period of use	Depending on chemical resistance Standard: 3 years	

The fill heads shown here are only exemplary representations. Depending on the equipment and configuration, the actual fill head may vary in appearance

4 Technical specifications

Materials (wetted components)

Characteristic	Value
Housing variants	Standard (natural): PE-HD, PVDF, PCTFE Conductive: PP (black), PVDF (black), PFA (black), stainless steel
O-ring variants	Standard: Perfluor elastomer (Kalrez®) As an alternative: FPM/FKM, EPDM

Materials (non-wetted components)

Characteristic	Value
Anti-rotation clip	PVC (red)
O-ring on code disk	Standard: FKM As an alternative: EPDM, Kalrez®
Other components	Standard: PVDF, As an alternative: PFA, on request

Connections

Characteristic	Value
Connection variants liquid	Flare: 3/8", 1/2", 3/4", 1", 1 1/4" Hose connector: 1/2", 3/4", 1" FNPT/MNPT: 1/2", 3/4", 1" G-thread: 1/2" Others on request (e.g. Tri-Clamp, Camlock, Pillar, Grundfos)
Connection gas	QC2: NPT 3/8" female thread (since November 2018) G-Series: NPT 1/2" female thread (since November 2018) Optional adapters, e.g. Flare adapters

- » Further information on the fill heads can be found in the corresponding data sheets. Possible other versions are available on request.

4 Technical specifications

4.2 Fill head DH-_B.../GH-_B..

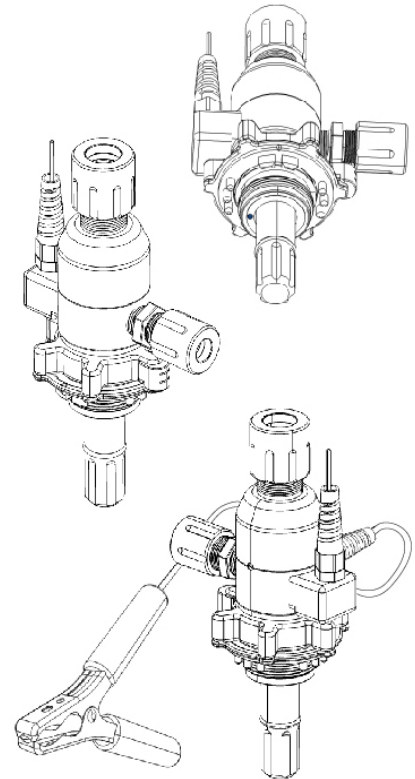
Characteristic	Value	Figure
Dimensions	See the corresponding data sheet for the fill head.	
Weight		
Tightening torque [Nm]	QC2: 2.6 G-Series: 2.6	
Flow rates [l/min]	QC2: <ul style="list-style-type: none">• max. 25 (with check valve)• max. 60 (without check valve) G-Serie: <ul style="list-style-type: none">• max. 100 (with check valve)• max. 150 (without check valve)	
Opening pressure check valve [bar]	QC2: 0.1 G-Series: 0.05	
Period of use	Depending on chemical resistance Standard: 3 years	

The fill heads shown here are only exemplary representations. Depending on the equipment and configuration, the actual fill head may vary in appearance

- » For electrical data, connection diagram and further information on integration, refer to the separate data sheet of the sensor.

4 Technical specifications

Materials (wetted components)

Characteristic	Value
Housing variants	Standard (natural): PE-HD, PVDF, PCTFE Conductive: PP (black), PVDF (black), PFA (black), stainless steel
O-ring variants	Standard: Perfluor elastomer (Kalrez®) As an alternative: FPM/FKM, EPDM
Release pin (limit switch)	Standard: Magnet encapsulated in PVDF As an alternative: Magnet encapsulated in PCTFE

Materials (non-wetted components)

Characteristic	Value
Anti-rotation clip	PVC (red)
O-ring on code disk	Standard: FKM As an alternative: EPDM, Kalrez®
Other components	Standard: PVDF, As an alternative: PFA, on request
Sensor	See data sheet of the sensor

Connections

Characteristic	Value
Connection variants liquid	Flare: 3/8", 1/2", 3/4", 1", 1 1/4" Hose connector: 1/2", 3/4", 1" FNPT/MNPT: 1/2", 3/4", 1" G-thread: 1/2" Others on request (e.g. Tri-Clamp, Camlock, Pillar, Grundfos)
Connection gas	QC2: NPT 3/8" female thread (since November 2018) G-Series: NPT 1/2" female thread (since November 2018) Optional adapters, e.g. Flare adapters

- » Further information on the fill heads can be found in the corresponding data sheets. Possible other versions are available on request.

4 Technical specifications

4.3 Fill head DH-A.../GH-A..

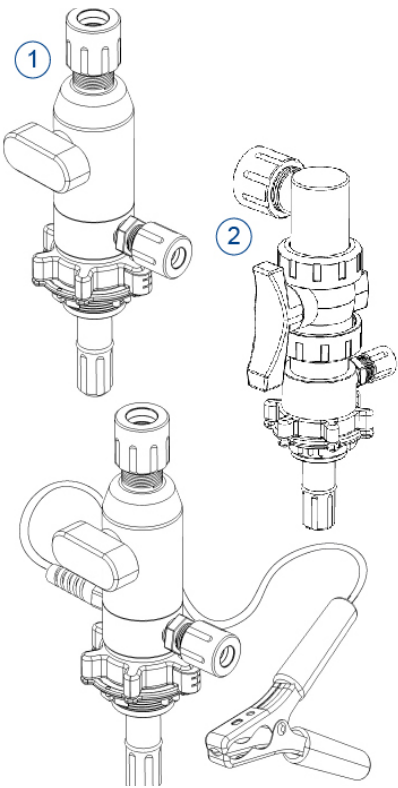
Characteristic	Value	Figure
Dimensions	See the corresponding data sheet for the fill head.	
Weight		
Tightening torque [Nm]	QC2: 2.6 G-Series: 2.6	
Flow rates [l/min]	QC2: <ul style="list-style-type: none">• max. 60 G-Series: <ul style="list-style-type: none">• max. 150	
Period of use	Depending on chemical resistance Standard: 3 years	

(1): Plug valve (turncock)
(2): Ball valve

The fill heads shown here are only exemplary representations. Depending on the equipment and configuration, the actual fill head may vary in appearance

- » Further information on the fill heads can be found in the corresponding data sheets. Possible other versions are available on request.

4 Technical specifications

Materials (wetted components)

Characteristic	Value
Housing variants	Standard (natural): PE-HD, PVDF, PCTFE Conductive: PP (black), PVDF (black), PFA (black), stainless steel
O-ring variants	Standard: Perfluor elastomer (Kalrez®) As an alternative: FPM/FKM, EPDM
Ball valve	For PE-HD housings <ul style="list-style-type: none">• Standard: PP-H with FPM o-rings• As an alternative: PP-H with EPDM o-rings, PP-H with Kalrez o-rings For PVDF housings <ul style="list-style-type: none">• Standard: PVDF with FPM o-rings• As an alternative: PVDF with EPDM o-rings, PVDF with Kalrez o-rings

Materials (non-wetted components)

Characteristic	Value
Anti-rotation clip	PVC (red)
O-ring on code disk	Standard: FKM As an alternative: EPDM, Kalrez®
Other components	Standard: PVDF, As an alternative: PFA, on request

Connections

Characteristic	Value
Connection variants liquid	Flare: 3/8", 1/2", 3/4", 1", 1 1/4" Hose connector: 1/2", 3/4", 1" FNPT/MNPT: 1/2", 3/4", 1" G-thread: 1/2" Others on request (e.g. Tri-Clamp, Camlock, Pillar, Grundfos)
Connection gas	QC2: NPT 3/8" female thread (since November 2018) G-Series: NPT 1/2" female thread (since November 2018) Optional adapters, e.g. Flare adapters

4 Technical specifications

4.4 Fill head DH-...-N2 / GH-...-N2

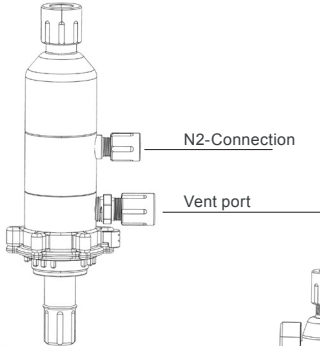
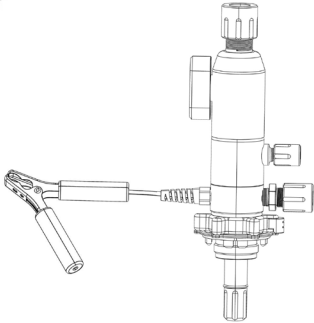
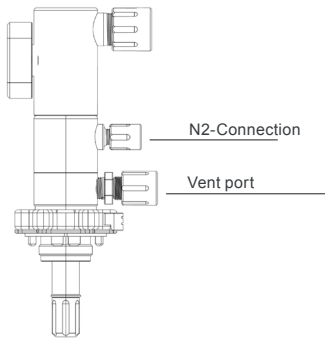
Characteristic	Value	Figure
Dimensions	See the corresponding data sheet for the fill head.	
Weight		
Tightening torque [Nm]	QC2: 2.6 G-Series: 2.6	
Flow rates [l/min]	QC2: <ul style="list-style-type: none"> • max. 25 (with check valve) • max. 60 (without check valve) G-Series: <ul style="list-style-type: none"> • max. 100 (with check valve) • max. 150 (without check valve) 	
Opening pressure check valve [bar]	QC2: 0.10 G-Series: 0.05	
Period of use	Depending on chemical resistance Standard: 3 years	

The fill heads shown here are only exemplary representations. Depending on the equipment and configuration, the actual fill head may vary in appearance

4 Technical specifications

Materials (wetted components)

Characteristic	Value
Housing variants	Standard (natural): PE-HD, PVDF, PCTFE Conductive: PP (black), PVDF (black), PFA (black)
O-ring variants	Standard: Perfluor elastomer (Kalrez®) As an alternative: FPM/FKM, EPDM
N2-tube	Standard: PE-LD As an alternative: PFA

Materials (non-wetted components)

Characteristic	Value
Anti-rotation clip	PVC (red)
O-ring on code disk	Standard: FKM As an alternative: EPDM, Kalrez®
Other components	Standard: PVDF, As an alternative: PFA, on request

Connections

Characteristic	Value
Connection variants liquid	Flare: 3/8", 1/2", 3/4", 1", 1 1/4" Hose connector: 1/2", 3/4", 1" FNPT/MNPT: 1/2", 3/4", 1" G-thread: 1/2" Others on request (e.g. Tri-Clamp, Camlock, Pillar, Grundfos)
Connection gas	QC2: NPT 3/8" female thread (since November 2018) G-Series: NPT 1/2" female thread (since November 2018) Optional adapters, e.g. Flare adapters
N2-connection	QC2: Flare 1/4", further upon on request G-Series: Flare 3/8", further upon on request

- » Further information on the fill heads can be found in the corresponding data sheets. Possible other versions are available on request.

4 Technical specifications

4.5 Fill head DH-_U... / GH-_U...

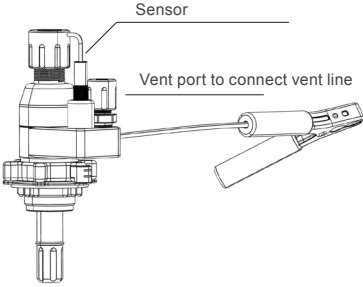
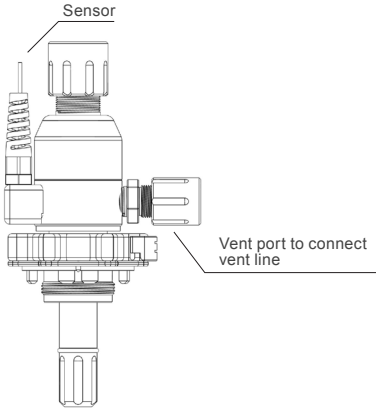
Characteristic	Value	Figure
Dimensions	See the corresponding data sheet for the fill head.	
Weight		
Tightening torque [Nm]	QC2: 2.6 G-Series: 2.6	
Flow rates [l/min]	QC2: <ul style="list-style-type: none"> • max. 25 (with check valve) • max. 60 (without check valve) G-Series: <ul style="list-style-type: none"> • max. 100 (with check valve) • max. 150 (without check valve) 	
Opening pressure check valve [bar]	QC2: 0.10 G-Series: 0.05	
Period of use	Depending on chemical resistance Standard: 3 years	

The fill heads shown here are only exemplary representations. Depending on the equipment and configuration, the actual fill head may vary in appearance

- » For electrical data, connection diagram and further information on integration, refer to the separate data sheet of the sensor.

4 Technical specifications

Materials (wetted components)

Characteristic	Value
Housing variants	Standard (natural): PE-HD, PVDF, PCTFE Conductive: PP (black), PVDF (black), PFA (black)
O-ring variants	Standard: Perfluor elastomer (Kalrez®) As an alternative: FPM/FKM, EPDM

Materials (non-wetted components)

Characteristic	Value
Anti-rotation clip	PVC (red)
O-ring on code disk	Standard: FKM As an alternative: EPDM, Kalrez®
Other components	Standard: PVDF, As an alternative: PFA, on request

Connections

Characteristic	Value
Connection variants liquid	Flare: 3/8", 1/2", 3/4", 1", 1 1/4" Hose connector: 1/2", 3/4", 1" FNPT/MNPT: 1/2", 3/4", 1" G-thread: 1/2" Others on request (e.g. Tri-Clamp, Camlock, Pillar, Grundfos)
Connection gas	QC2: NPT 3/8" female thread (since November 2018) G-Series: NPT 1/2" female thread (since November 2018) Optional adapters, e.g. Flare adapters

- » Further information on the fill heads can be found in the corresponding data sheets. Possible other versions are available on request.

4 Technical specifications

4.6 Fill head DH-_J... / DH-J... / GH-_J... / GH-J...

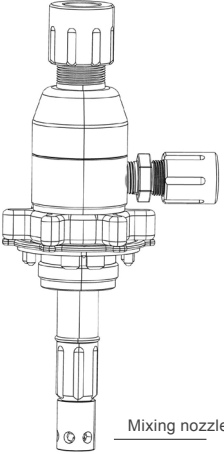
Characteristic	Value	Figure
Dimensions	See the corresponding data sheet for the fill head.	
Weight		
Tightening torque [Nm]	QC2: 2.6 G-Series: 2.6	
Flow rates [l/min]	QC2: <ul style="list-style-type: none"> • max. 25 (with check valve) • max. 60 (without check valve) G-Series: <ul style="list-style-type: none"> • max. 100 (with check valve) • max. 150 (without check valve) 	
Opening pressure check valve [bar]	QC2: 0.10 G-Series: 0.05	
Period of use	Depending on chemical resistance Standard: 3 years	

The fill heads shown here are only exemplary representations. Depending on the equipment and configuration, the actual fill head may vary in appearance

4 Technical specifications

Materials (wetted components)

Characteristic	Value
Housing variants	Standard (natural): PE-HD, PVDF, PCTFE
O-ring variants	Standard: Perfluor elastomer (Kalrez®) As an alternative: FPM/FKM, EPDM

Materials (non-wetted components)

Characteristic	Value
Anti-rotation clip	PVC (red)
O-ring on code disk	Standard: FKM As an alternative: EPDM, Kalrez®
Other components	Standard: PVDF, As an alternative: PFA, on request

Connections

Characteristic	Value
Connection variants liquid	Flare: 3/8", 1/2", 3/4", 1", 1 1/4" Hose connector: 1/2", 3/4", 1" FNPT/MNPT: 1/2", 3/4", 1" G-thread: 1/2" Others on request (e.g. Tri-Clamp, Camlock, Pillar, Grundfos)
Connection gas	QC2: NPT 3/8" female thread (since November 2018) G-Series: NPT 1/2" female thread (since November 2018) Optional adapters, e.g. Flare adapters

- » Further information on the fill heads can be found in the corresponding data sheets. Possible other versions are available on request.

4 Technical specifications

4.7 Ambient / operating temperature

Housing material	Temperature	
	Environment	Operation
PE-HD, PP	20-40 °C (68-104 °F)	20-40 °C (68-104 °F)
PVDF	20-60 °C (68-140 °F)	20-60 °C (68-140 °F)
PFA, PCTFE, stainless steel	20-60 °C (68-140 °F)	20-60 °C (68-140 °F)

For applications outside the listed temperature ranges, please contact the technical customer service of AS Strömungstechnik.

The chemical resistance of plastics and elastomers can deteriorate due to heat at temperatures higher than room temperature.

For fill heads with built-in sensors (e.g. limit switch), also observe the temperature specifications given in the sensor data sheet. These may further restrict the temperature ranges listed here.

4.8 Torques for dip tube closures

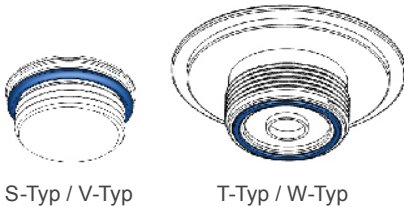

S-Typ / V-Typ

T-Typ / W-Typ

QC2

Closure type	Torque
S-Typ/V-Typ (3/4" plug)	5-6 Nm
T-Typ/W-Typ (M42 plug).	6-8 Nm

G-Series

Closure type	Torque
S-Typ/V-Typ (1" plug)	5-6 Nm

In the containers onto which the fill heads are mounted, there is already the dip tube on which the fill head is mounted. The dip tube is key-coded according to the liquid in the container or with the universal code 20 for recirculation applications and is tightly closed by means of the closure. Depending on the closure, it can also be closed with a tamper-proof cap. For the assembly described below, it is assumed that the closure is secured with a tamper-proof cap.

5.1 Initial commissioning

1. Make sure that the entire system is in a clean environment.

NOTICE

Contamination and build-up can restrict the functionality of the entire system and lead to premature wear of o-rings and seals and thus to leaks. Dust deposits must be avoided in EX areas in particular, as there is an increased risk of ignition.

2. Connect the fill line to the liquid connection of the fill head. The following must be observed here:
 - The fill line must be connected free of stress and load.
 - The connecting couplings must not be tightened too tight or too loose. Both can lead to leaks.
 - Please use recommended torque specifications of the respective manufacturer when tightening nuts and screws.
 - The screw connections must be secured against unwinding.
 - When using flare connections, see also AS flare and assembly instructions.
 - If the fill line is installed horizontally, it should be supported approx. 50 cm away from the fill head.
 - The vibrations of the fluid pump must not be transmitted to the fill head via the fill line.
 - The vertical liquid column above the fill head should be as small as possible.

3. Connect the ventilation line to the vent port of the fill head.

CAUTION

Danger due to leaks!

Exceeding the maximum permissible pressure can lead to leakage.

- Take suitable protective measures against exceeding the maximum permissible pressure. Please also note the specifications of the container manufacturer.

- » The vent port is used only to connect a ventilation line. Never use it as a return flow for liquids.
 - » With fill heads, the vent port is used to relief pressure build up inside the container while filling.
4. Check whether the container can be inerted with nitrogen before the filling process.
 - » In the case of fill heads with a second gas connection, nitrogen can be introduced through this second connection. The excess nitrogen in the container escapes through the vent connection.
If inerting is carried out in combination with a long dip tube in empty containers, the nitrogen cushion builds up from the bottom in the container.
 - » In recirculation applications, in which a dispense head and a fill head are attached to the container, the standard ventilation connections can be used to inert the container with nitrogen before operation.
5. Mount the fill head on a empty container or for recirculation applications in combination with a dispense head on a container filled with ultra pure water. For assembly, see the section „Mounting the fill head“.
6. Perform a test run with ultra pure water and check the following points:
 - Tightness of the connections and interfaces,
 - Closing behavior of the valves; the valves (check valve, plug valve (turncock) or ball valve) must seal completely,
 - Ventilation of the container at maximum flow rate.
If no pressure range is available/measurable, visually check that the flow rate is constant and that the container does not inflate or collapse.
 - » A fill head with a manual shut-off valve can be used for pressureless filling.

CAUTION

Danger due to leaks!

Exceeding the maximum flow rate can lead to leakage.

- Take suitable protective measures against exceeding the maximum flow rate.

7. Check/test the chemical resistance of the fill head for the chemical used.
 - » On our website you will find a database with some data on chemical resistance, which can be used as a guide.
Link: <https://asstroemungstechnik.de/de/chembank>
8. Check whether the fill head shows any damage such as cracks or discoloring.
9. Use the first liters of product as flushing chemistry to condition the fill head and connections.
10. In the case of fill heads with overfilling sensors, it must be checked whether the medium to be filled is detected by the sensor.

5.2 Tests prior to assembly

1. Use the label on the container to check whether the desired chemical is in the container.
 - » In addition, an electronic chemical comparison should be carried out via barcode or RFID.
2. Make sure that the container is placed in a dust-free environment.

NOTICE

Contamination and debris can limit the functionality of the fill head and lead to premature wear of seals and thus to leaks.

3. Carry out a visual inspection for the following points:
 - Contamination and adhesion of chemical residues. The fill head must be clean.
 - Make sure there is no damage such as cracks, etc.

WARNING

Hazard from chemicals!

A closed or incorrectly connected ventilation line will cause the pressure equalization in the container to fail. Excess or negative pressure can occur in the container. Chemicals may leak out.

- Make sure that the ventilation line is not blocked and is correctly connected.
 - Wear the necessary personal protective equipment (PPE) (suitable protective clothing, protective gloves, respirators and safety goggles / face shield).
4. Check that the ventilation line is connected to the vent port and that the ventilation line is free, i.e. not blocked or kinked.
 5. Check the connecting couplings. They must not be too tight or too loose.
 - » Use the correct tightening torque that matches the screw connection. Please use recommended torque specifications of the respective manufacturer when tightening nuts and screws.
 - » The screw connections must be secured against unwinding. When using flare connections, see also AS flare and assembly instructions.

6. Check that the o-rings (1), (2) and (3) are in place and undamaged e.g. cracks, tears, and residue are signs of damage.

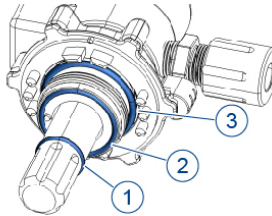

7. Check that the locking pin (4) is in place between the two parts of the housing and is undamaged.

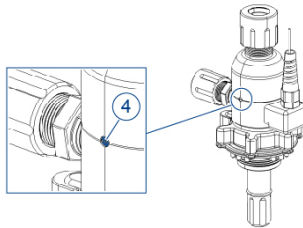

CAUTION

Danger due to leaks!

If the top and main body do not line up this can be a sign that it has been tampered with and could result in leaks.

8. Check that there is a code disk (5) on the fill head and that the coding matches that of the dip tube (6) and thus the chemical. This means that only the correct three pins (7) must be missing and the code disk must not be bent.

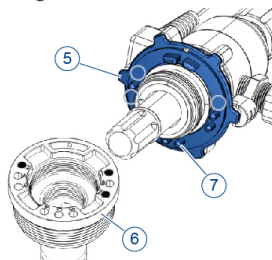

- » Do not change any coding on the dip tube or the code disk if they do not match. A list of the possible codings is available on request.
9. If available, check whether the connected valves and filters are free and functional.

10. For fill heads with limit switch, check whether the release pin (8) is present and functional.

NOTICE

The release pin can stick or harden due to the influence of chemicals. Therefore do not use the limit switch with adhesive, hardening or crystallizing chemicals.

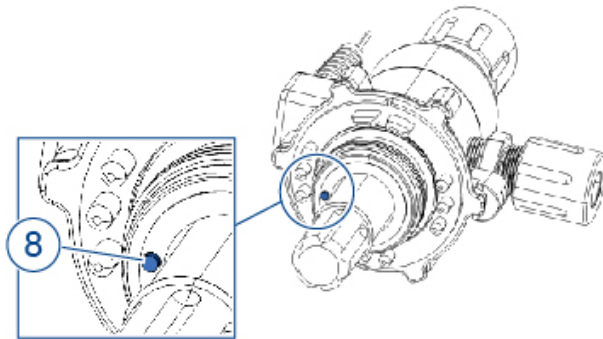

11. In the case of conductive fill heads, check whether a conductive dip tube is installed and whether it is properly grounded.
Follow the ATEX and OSHA instructions and regulations.
 - » For further information, please refer to the operating instructions of the dip tube.
12. When using fill heads with an overfilling sensor, check whether the sensor in the housing is working properly. The ventilation channel must be free of any debris of the medium so that the measuring field of the sensor is not disturbed. A ventilation line must be connected to the vent port so that no medium can escape unhindered in the event of overfilling.

5.3 Mounting the fill head

WARNING

Hazard from chemicals!

Chemicals can cause irritation and chemical burns.

- Observe the proper Standard Operating Procedures (SOP) when handling hazardous substances.
- Observe the safety data sheets (SDS) of the chemicals used.
- Wear the necessary personal protective equipment (PPE) (suitable protective clothing, protective gloves, respirators and safety goggles / face shield).

1. If a tamper-proof cap is fitted to the dip tube closure of the container, remove the blue seal on the original tamper-proof cap (1).

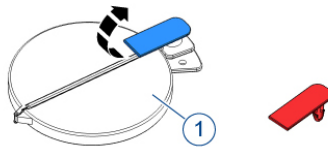

2. Open the tamper-proof cap and remove the red seal. Place both, if available, in the docking station on the system side (see Section 3.1).

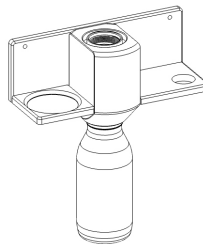

WARNING

Inhalation of chemical gases!

Inhalation of chemical gases is a health hazard.

- Open the container only while the chemical gas is being extracted.
- Please observe the applicable threshold limit values.
- Wear the necessary personal protective equipment (PPE) (suitable protective clothing, protective gloves, respirators and safety goggles / face shield).

3. Slowly open the dip tube closure (2) with the bung wrench (3) in case the contents are under pressure. (See Section 3.1)

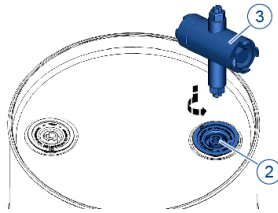

- » If the container is under pressure when opened, it is drained via the ventilation holes in the dip tube. You may hear a hissing sound. In this case, do not open the dip tube closure any further, but wait until no more hissing can be heard.
 - » Check whether a bung wrench with a special chamber for neutralization granulate can be used so that the escaping gases can be additionally neutralized when opening.
 - » If the chemical escapes when the container is opened, the container has been overfilled by the chemical filler. If this is the case, close the container again immediately and contact the chemical filler / manufacturer / supplier.
4. Remove the fill head, if present, from the system-side docking station.
 5. For fill heads with plug valve (turncock), ball valve or outlet tap, check that the manual shut-off valve is closed.

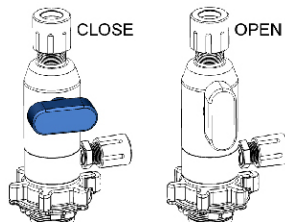

6. Wet the o-ring (4) with ultra pure water.

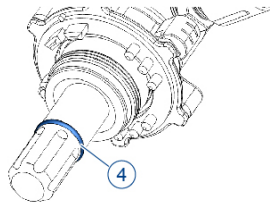

- » Wetting with ultra pure water minimizes sliding friction and protects the o-ring from damage.

7. Make sure that electrically conductive fill heads are properly grounded with ground wire and terminal.
8. Insert the fill head into the dip tube.

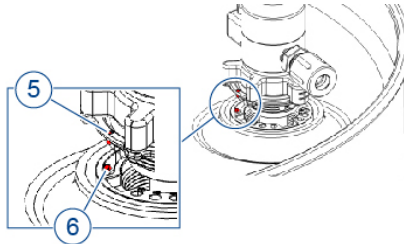

9. Align the code disk using the red or green orientation pins (5) and (6).
 - » The orientation pin of the dip tube and the code disk must be on top of each other.

NOTICE

The code disk must not be bent or damaged. Never mount the code disk using force.

10. Press the code disk into the recess of the dip tube.
11. Before screwing it on, make sure that the fill head is not set at an angle to avoid tilting and damaging the threads.
12. Screw on the fill head with the tightening nut (7) using the torque tool (8) (see Section 3.1) with the correct torque.
 - QC2: 2.6 Nm
 - G-Series: 2.6 Nm

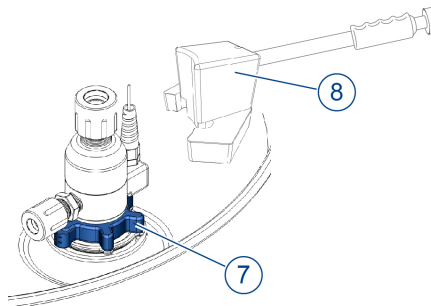

13. Check that the fill head is completely and correctly mounted. This means that the fill head must e.g. not be inserted at an angle.
 - » Check whether further precautions must be taken to ensure this, e.g. by using a fill head with limit switch or by using a light barrier.
14. Press the anti-rotation clip (9) downwards.
 - » The tightening nut can only be moved within the two lugs of the code disk between which the anti-rotation clip is located.

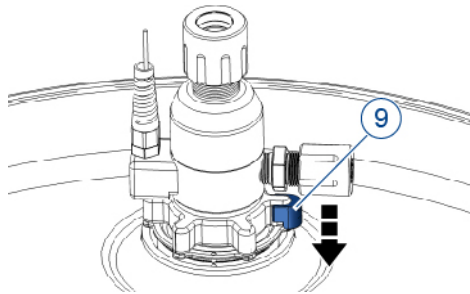

15. Check again that the head is correctly inserted and tightened.

WARNING

Hazard from chemicals!

If the head is not completely screwed on, vapors or chemicals can escape via the dip tube and fill head connection and not through the dedicated vent and liquid ports.

16. Check from all sides that the code disk lies flat on the dip tube (10).

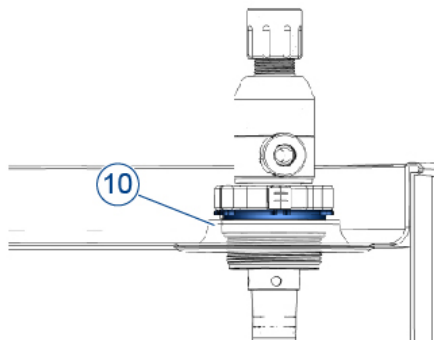

6.1 Tests before each operation

1. Make sure that minimal to no vibrations, e.g. from the fluid pump, are transmitted to the entire system.
2. For electrically conductive fill heads, check that the entire system is grounded. The grounding of the fill head is done via the ground wire with the clamp. The ground wire with the terminal must be free of corrosion.
 - » Follow the ATEX and OSHA instructions and regulations.

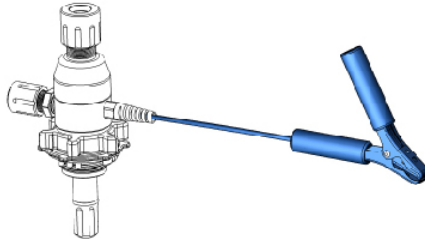

3. Make sure that the fill head is correctly mounted.
4. For fill heads with plug valve, ball valve or outlet tap, open the manual shut-off valve as soon as the system is connected.

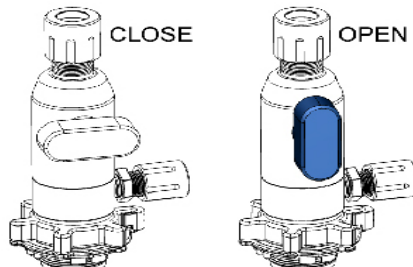

5. Operation can be started.

6.2 Tests during operation

- Check the flow rate and regulate it so that no negative or excess pressure can develop in the container.
If no pressure range is available/measurable, visually check that the flow rate is constant and that the container does not inflate or collapse.
- Check that minimal to no vibrations are transferred to the overall system.
- Carry out a visual inspection of the overall system for leaks or damages.

Error	Possible cause	Remedy
Container builds excessive pressure during operation and/ or when the system is stopped.	Ventilation connection of the fill head closed or ventilation line not free (e.g. blocked particle filters, blocked valves, kinked line).	Check and clear the entire ventilation line, replace particle filter or valves if necessary.
	Ventilation of the container is not sufficient to achieve complete pressure equalization.	Reduce the filling flow rate of the operating medium, Increase the nominal diameter of the ventilation line, Shorten the length of the ventilation line, see also Chapter 5.
Container contracts when the system is stopped.	Ventilation line is connected to a suction system, which creates excessive negative pressure in the container.	Take suitable precautions on the system side to prevent negative pressure, e.g. reduce the negative pressure in the extraction system.
Fill head can only be screwed into the dip tube at an angle or not completely.	Thread on dip tube damaged.	Contact chemical filler / manufacturer / supplier or technical customer service of AS Strömungstechnik
	Thread on the fill head damaged.	Contact AS Strömungstechnik technical customer service, send in the fill head for repair, see Section 9.3.
Operating medium escapes from fill head outlet (liquid channel).	Contaminations/deposits in the valve.	Clean/rinse the fill head.
	Valve body or seal damaged.	Contact AS Strömungstechnik technical customer service, send in the fill head for repair, see Section 9.3.
	Pressure from the liquid column above the valve too high.	Reduce the vertical liquid column above the fill head.

8.1 Dismantling the fill head

WARNING

Hazard from chemicals!

Chemicals can cause irritation and chemical burns.

- Observe the proper Standard Operating Procedures (SOP) when handling hazardous substances.
- Observe the safety data sheets (SDS) of the chemicals used.
- Wear the necessary personal protective equipment (PPE) (suitable protective clothing, protective gloves, respirators and safety goggles / face shield).

1. Make sure that there is no positive pressure in the fill line.
 - » Positive pressure in the fill line would result in the check valve being pushed open and causing liquid to flow out of the fill head and create a spill in the filling area.
2. For fill heads with plug valve (turncock), ball valve or outlet tap, close the manual shut-off valve.

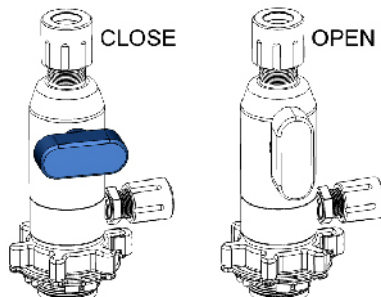

8 Demontage

3. Push the anti-rotation clip (1) upwards.

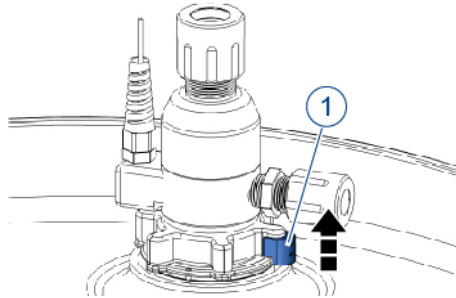

4. Slowly unscrew the fill head via the tightening nut.
 - » If the container is under any pressure or vacuum when opened, it is drained via the ventilation hole in the dip tube. You may hear a hissing sound. In this case, do not continue unscrewing the fill head, wait until no more hissing can be heard and then finish unscrewing.
5. Pull the fill head out of the dip tube until the fill head is above the dip tube opening.

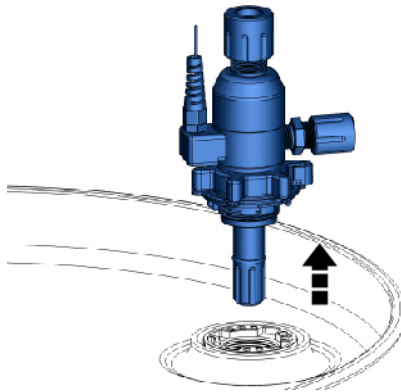

6. Wait a few seconds so that condensate, for example, can still drip into the container.
7. Rinse and clean the fill head with ultra pure water.
8. Insert the fill head, if present, into the docking station on the system side.
9. Screw the fill head in tight into the docking station.

8 Demontage

10. Check that the o-ring on the dip tube closure is present and undamaged.

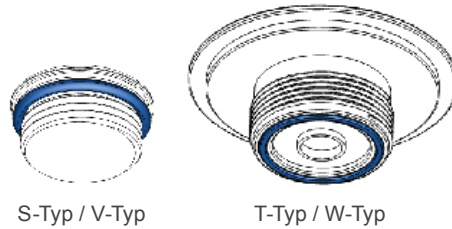

11. Place the dip tube closure on the dip tube opening.
12. Close the container by screwing on the dip tube closure (2) hand-tight using the bung wrench (3) (see Section 3.1).

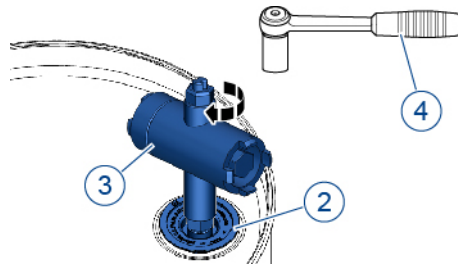

13. Take a torque wrench (4), place it on the bung wrench (3). Tighten the dip tube closure (2) to the correct torque.
 - » See the table with the torques in Section 4.6.
14. Close the dip tube closure with the tamper-proof cap and seal it with the red seal.



9.1 Cleaning the fill head

- After disassembly, the liquid channel of the fill head must be flushed with ultra pure water or a suitable flushing medium.
- In the case of hardening, adhesive and clumping chemicals, we recommend flushing the entire delivery line with ultra pure water or a suitable flushing medium after each use.
- If necessary, wash the fill head from the outside with ultra pure water or a suitable rinsing medium.

9.2 Fill head maintenance

The following checks must be carried out regularly, at least monthly, in addition to the checks during assembly:

Component	Testing
Fill head	Check regularly for discoloration and damage.
Check valve	Regular functionality check.
O-rings on the fill head	Regularly check for wear and tear and replace if necessary.
Electrical conductivity	For CD version, check conductivity regularly (may change due to exposure to chemicals).
O-ring on check valve	Regularly check whether the check valve seals completely.
Tap / ball valve / shut-off valve	Regular function check.
Fill head	Regularly check the connections for proper screw connections.
Overfilling sensor	Regular function check.

9.3 Returning fill heads

1. Disassemble the fill head (see Section “8.1”).
2. Clean the disassembled fill head (see Section 9.1).
3. Request a decontamination certificate from AS Strömungstechnik.
4. Return the completed decontamination certificate to AS Strömungstechnik.
 - » If the decontamination certificate is not properly and completely filled out, there will be no credit provided or repair. A disposal cost will be applied. It is important to fill out the form for the safety of our personnel as well as the safety of logistic providers.

9.4 Fill head disposal

WARNING

Hazard from chemicals!

Chemicals can cause irritation and chemical burns.

- Observe residual debris and degassing of diffused chemicals.
- Observe the safety data sheets (SDS) of the chemicals used.

1. Disassemble the fill head (see Section “8.1”).
2. Clean the disassembled fill head (see Section 9.1).
3. Dispose of all parts in an environmentally correct manner.



Incorrect or negligent disposal can cause considerable environmental pollution.

- Disposal must take place in accordance with the applicable national rules and regulations.

In case of doubt, consult the manufacturer or obtain information on the environmentally responsible disposal from the local authorities or disposal specialists.

